

# F-series scroll condensing units

*For medium and low temperature refrigeration applications*





	Page
Disclaimer and safety information	4
Nomenclature	7
Features	8
Physical layout of the unit	9
Pre-installation guideline	10
Mechanical data - 50Hz	11
Mechanical data - 60Hz	12
Installation, system processing and commissioning	13
User operation	16
Maintenance	18
Wiring diagrams	19

Thank you for purchasing the Copeland scroll F-series indoor condensing unit. We hope that this product meets your refrigeration needs efficiently and effectively.

Please read through this User Manual thoroughly to familiarize yourself with the installation and commissioning process of this product and how to use it optimally. Please do read the following information in this page before proceeding with the rest of the manual.

The Copeland F-series refrigeration condensing units should only be installed by suitably qualified and experienced refrigeration technicians. No responsibility can be accepted for damage caused by inexperienced or inadequately trained site technicians or improper system design. All instructions and procedures described in this manual are based on good refrigeration trade practices as applicable to this particular product. The installation contractor may prefer to use variations to these recommendations. However, the methods described in this manual represent the minimum requirements to avoid any subsequent warranty claims for this equipment and its components. These instructions do not cover the fundamentals of good electrical or refrigeration practice and are therefore intended for use only by qualified and/or experienced personnel or technicians.

These instructions are general in nature for this family of products and due to our policy of continuous improvement, some of the details may not apply to the unit you are installing. If in doubt, please consult your local sales office, quoting unit model, and serial number as shown on the nameplate. In case of ambiguity, the wiring diagram supplied with each unit takes precedence over the diagram in this manual.

### **Important**

The information contained in this manual is critical to the correct operation and maintenance of the condensing unit and should be read by all persons responsible for the installation, commissioning, and maintenance of this unit.

### **Safety**

The equipment has been designed and manufactured to meet international safety standards but, like any mechanical/ electrical equipment, care must be taken if you are to obtain the best results.

### **Caution**



1. Service and maintenance of this unit, that is, Electrical and Mechanical in nature should be carried out by technically trained and competent personnel. They should be familiar with Local Standards and Codes of Practice.
2. When carrying out unit maintenance, ensure that the equipment is disconnected from the electrical power supply.
3. Refrigerant used in this unit is classified under the COSHH regulations as an irritant, with set Occupational Exposure Levels (OEL) for consideration if installed in confined or poorly ventilated areas.

### **General instructions**

### **Warning**



**Risk of collapse! Personal injuries!** Move condensing units with the correct mechanical handling equipment. Keep the units in the upright position. For storage stack units, one on top of the other (max. 2 high). For transport, do not stack at all. Keep the packaging dry at all times.

**Rapid release of pressurised gas! Personal injuries!** Units are factory charged with pressurised dry air to between 1.5 and 2 bar to ensure no ingress of air or moisture during transit. Pressure must be safely reduced prior to fully opening connections or removing blanking components.

**System breakdown! Personal injuries!** Systems without a full charge or with the service valves closed should be electrically locked/tagged if left unattended. Only approved refrigerants and refrigeration oils must be used. Never block the condenser fins, ensure continual airflow through the condenser.

**High pressure! Injury to skin and eyes possible!** Be careful when opening up a pressurized component or system.

**High pressure! Personal injuries!** Use of safety relief valves according to EN 378 is mandatory. Consider personal safety requirements and refer to test pressures prior to test.

**Rotating machinery! Personal injuries!** When the unit is running, do not put your hand inside the unit or remove the fan guard, protective covers etc. Electrically isolate the unit removing fuses before working on the unit.

### Warning



**Conductor cables! Electrical shock!** Shut off the power supply and remove all of the fuses before working on the electrics.

### Warning



**Diesel effect! Compressor destruction!** The mixture of air and oil at high temperature can lead to an explosion. Avoid operating with air.

**System explosion! Personal injuries!** DO NOT USE other industrial gases.

**Explosive flame! Burning!** Oil/refrigerant mixtures are highly flammable. Remove all refrigerant before opening the system. Never work with a naked flame on a refrigerant charged/pressurized system.

### Warning



**High surface temperature! Burning!** Do not touch the compressor or system pipe-work until they have cooled down. Ensure that other materials in the area of the compressor do not get in contact with it. Mark and secure accessible sections.

**Low surface temperatures! Frostbite!** Do not touch any surface or pipe-work of the system until they are at room temperature. Mark and secure accessible sections.

## ***Receiving your unit***

All units are shipped with a holding charge of Inert Gas inside at a low but positive pressure. Suitable labeling is prominently displayed on both the unit and the packaging. Service connectors are provided on the CDU service valve for the convenient checking of the integrity of the holding charge.

### **Caution**



It is very important to check that this holding pressure exists at the time you receive each unit from us or our authorized representatives. Please inform us or our authorized representative if the holding charge is non-existent. Failure to do so could void the claim for other related system faults at a later period. Transit damage is essentially an insurance claim and is not covered under manufacturing defect. It is also advisable to inspect the rest of the unit for obvious physical damage and inform us or our authorized representative in case any is discovered.

***F-series scroll condensing unit was designed based on key features demanded by industry users:***

- Wide operating envelope
- Low applied cost - factory built
- Compact design
- Optimal layout of components for easy serviceability
- Energy efficient silent fans
- Condenser coils options available for both moderate and high ambient conditions
- Liquid receiver, HP/LP switch as standard feature
- Local availability
- Pre-wired electrical junction box
- Copeland scroll compressor
  - Proven reliability
  - Lower sound levels and pulsations
  - Dual compliance for superior efficiency and better liquid handling

***Nomenclature***

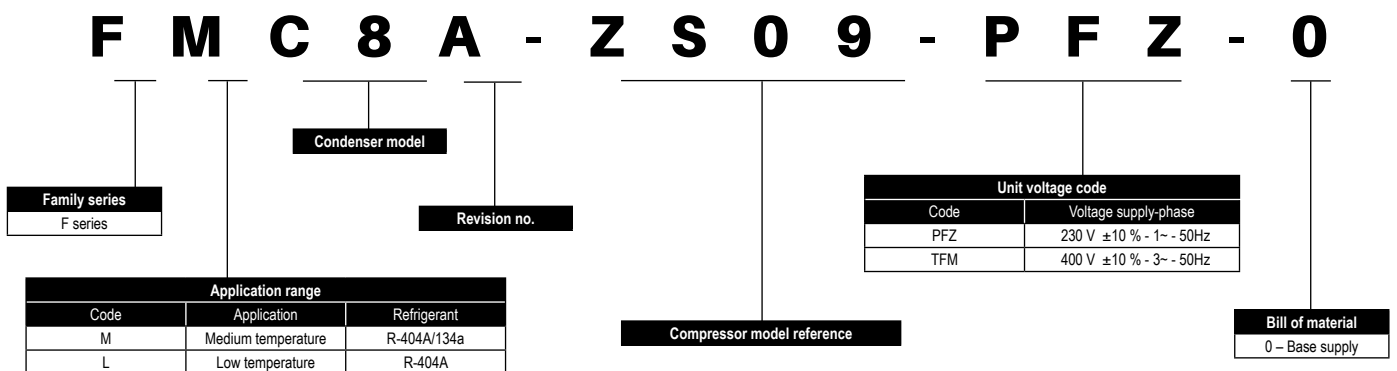

***Scope of supply***

- HP/LP switch
- Crankcase heater
- Liquid receiver

**Dual compliance**

Compliance means sealing between the orbiting and fixed scroll involutes. Dual compliance means the sealing is on both the axial and radial directions. This prevents refrigerant leak back across successive scroll pressure pockets. Compliance design also allows the scroll involutes to separate in both the radial and axial directions. This allows debris or liquid refrigerant to pass through the scroll involutes without damaging the compressor. Benefits of dual compliance are:

- Increased efficiency
- Better liquid handling capability
- Better handling of debris

**Scroll wear-in**

The scroll involutes of Copeland scroll compressor wear-in, rather than wear-out. So unlike in other compressor technologies among similar categories, there is no constant degradation of performance with time due to wear-out.

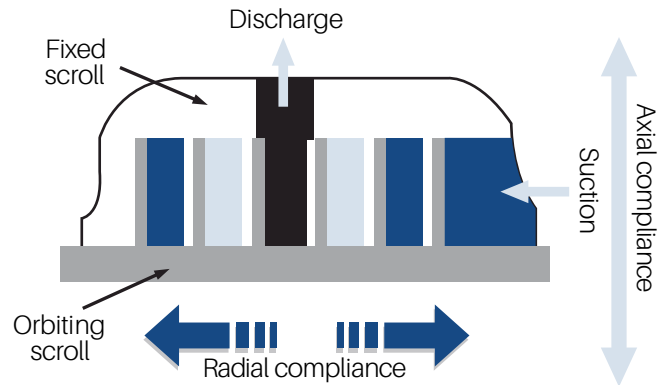

Figure 1

**Lower sound, vibration and pulsation**

The compression process in a scroll set is symmetrical and continuous. This inherently reduces the sound, vibration and pulsation. This eliminates the need for use of vibration absorbers and suction or discharge mufflers in most of the applications. Further, ZB scroll compressors are engineered to produce smooth sound spectrum which improves the quality of sound.

**Unloaded start**

The scroll sets separate at the instant of compressor shutdown. This allows the scroll set internal pressures to equalize on compressor stops. In addition to this, the scroll sets are not engaged at the instant of starting. Scroll sets engage only after few milliseconds of startup. This allows easier startup of ZB scroll compressors. Due to this design feature, typically a start assist kit is not required even on single phase compressors.

**DU bearings**

A space age bearing material comprising of porous bronze with PTFE-lead overlay. These bearings are used in ZB scroll compressors in the scroll drive and main bearings. DU bearings work with exceptionally low friction between the load bearing surfaces. In addition, DU bearings can operate safely for a short time with loss of lubrication. This situations could happen on compressor applications due to oil pump out during a flooded start or heavy oil dilution after a defrost cycle.

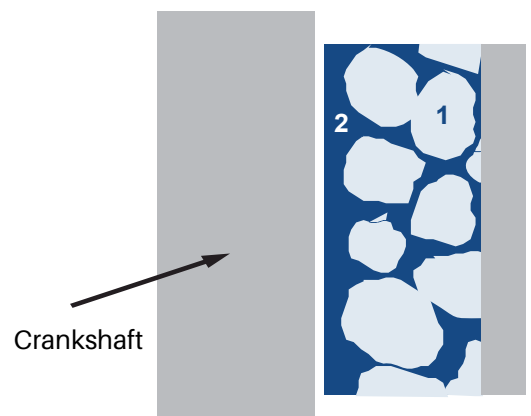
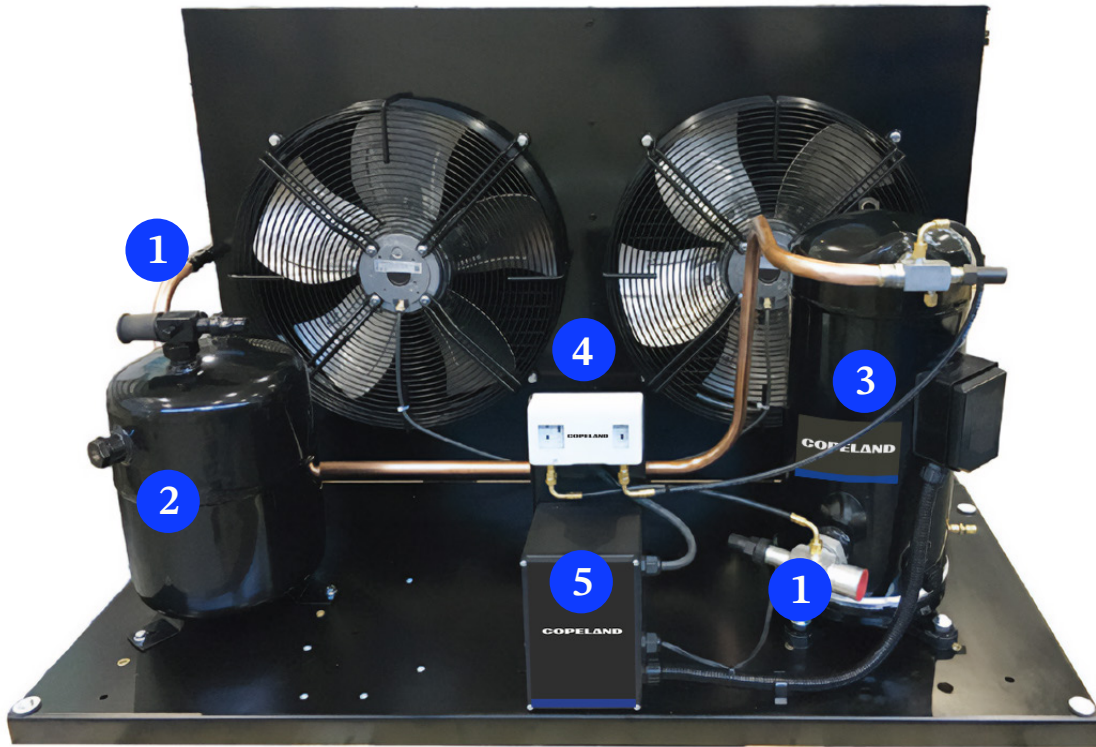

Figure 2





1. Service valves for customer connection
2. Liquid receiver
3. Scroll compressor
4. HP/LP cutout
5. Junction box

### Transport and storage

Move F-series unit only with appropriate mechanical or handling equipment according to weight. Keep in the upright position. Do not stack single boxes on top of each other without pallet in any case. Keep the packaging dry at all times.

### Unit lifting

If the unit is dropped, it should immediately be checked for damage.

### Caution



The unit should be lifted from the base and, where possible, with all packing and protection in position.

***The installation position should be selected with the following points in mind:***

- Leveling should be +/- 5 mm.
- Pipework and electrical connections are readily accessible.
- Ensure there are no obstructions in front of the condenser inlet.

It is recommended to have a clearance of at least 500mm between the condenser face and adjacent wall or unit.

Where multiple units are to be installed in the same location, the contractor needs to consider each individual case carefully.

Due care should be taken to avoid the discharge air from each unit adversely affecting other units in the vicinity.

There can be many variations of unit quantities and available space and this manual does not cover all such possible options. In general terms, air recirculation and local heat build up should be avoided at all times.

**Caution**



The unit should never be installed adjacent to a dust source (such as a dirty road or extractor fan). External contamination of the condenser fins lead to high condensing temperatures and will reduce the life of the unit.

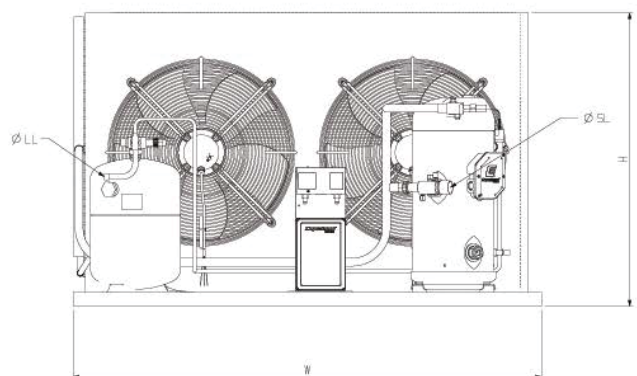
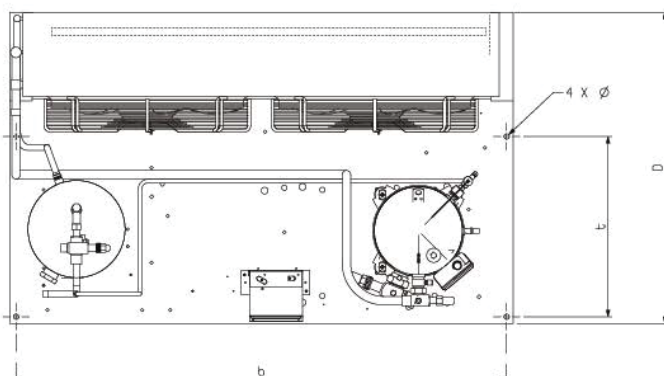
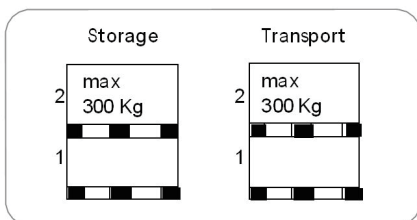

## Mechanical data - 50Hz

	Condensing unit model	Compressor model	Gross weight (kg)	b	t	D	W	H
Medium temperature	FMV9A-ZB 58-TFM	ZB58KQE-TFD-551	225	1294	475	820	1329	832
	FMV9A-ZB 66-TFM	ZB66KQE-TFD-551	230	1294	475	820	1329	832
	FMV6A-ZB 66-TFM	ZB66KQE-TFD-551	247	1294	475	820	1329	832
	FMV6A-ZB 76-TFM	ZB76KQE-TFD-551	248	1294	475	820	1329	832
	FMV6A-ZB 95-TFM	ZB95KQE-TFD-551	252	1294	475	820	1329	832
	FMC8A-ZS 09-PFZ	ZS09KAE-PFJ-600	55	530	330	570	560	444.04
	FMC8A-ZS 09-TFM	ZS09KAE-TFD-600	55	530	330	570	560	444.04
	FMC8A-ZS 11-PFZ	ZS11KAE-PFJ-600	55	530	330	570	560	444.04
	FMC8A-ZS 11-TFM	ZS11KAE-TFD-600	55	530	330	570	560	444.04
	FMD8A-ZS 11-PFZ	ZS11KAE-PFJ-600	55	530	330	570	560	444.04
	FMD8A-ZS 11-TFM	ZS11KAE-TFD-600	55	530	330	570	560	444.04
	FMD8A-ZB 15-TFM	ZB15KQE-TFD-559	58	530	330	570	560	444.04
	FMH7A-ZB 15-TFM	ZB15KQE-TFD-559	79	700	370	679.5	735	531
	FMH7A-ZB 19-TFM	ZB19KQE-TFD-559	81	700	370	679.5	735	531
	FMH8A-ZB 19-TFM	ZB19KQE-TFD-559	81	700	370	679.5	735	531
	FMH8A-ZB 21-TFM	ZB21KQE-TFD-559	83	700	370	679.5	735	531
	FMM8A-ZB 21-TFM	ZB21KQE-TFD-559	93	700	390	730	735	707.04
	FMH8A-ZB 26-TFM	ZB26KQE-TFD-559	82	700	370	679.5	735	531
	FMM8A-ZB 26-TFM	ZB26KQE-TFD-559	92	700	390	730	735	707.04
	FMM8A-ZB 29-TFM	ZB29KQE-TFD-559	93	700	390	730	735	707.04
	FMR6A-ZB 29-TFM	ZB29KQE-TFD-559	135	1095	475	820	1130	630
	FMR6A-ZB 38-TFM	ZB38KQE-TFD-559	143	1095	475	820	1130	630
	FMR7A-ZB 38-TFM	ZB38KQE-TFD-559	143	1095	475	820	1130	630
	FMR7A-ZB 45-TFM	ZB45KQE-TFD-559	148	1095	475	820	1130	630
	FMS9A-ZB 45-TFM	ZB45KQE-TFD-559	158	1095	475	820	1130	706
	FMR7A-ZB 48-TFM	ZB48KQE-TFD-559	147	1095	475	820	1130	630
	FMS9A-ZB 48-TFM	ZB48KQE-TFD-559	157	1095	475	820	1130	706
	FMS9A-ZB 58-TFM	ZB58KQE-TFD-551	175	1095	475	820	1130	706

	Condensing unit model	Compressor model	Gross weight (kg)	b	t	D	W	H
Low temperature	FLD8A-ZF 06-TFM	ZF06K4E-TFD-551	58	530	330	570	560	444.04
	FLD8A-ZF 09-TFM	ZF09K4E-TFD-551	60	530	330	570	560	444.04
	FLH7A-ZF 09-TFM	ZF09K4E-TFD-551	81	700	370	679.5	735	531
	FLH7A-ZF 11-TFM	ZF11K4E-TFD-551	82	700	370	679.5	735	531
	FLH8A-ZF 11-TFM	ZF11K4E-TFD-551	82	700	370	679.5	735	531
	FLH8A-ZF 13-TFM	ZF13KQE-TFD-551	92	700	370	679.5	735	531
	FLM8A-ZF 13-TFM	ZF13KQE-TFD-551	102	700	390	730	735	707.04
	FLM8A-ZF 15-TFM	ZF15KQE-TFD-551	103	700	390	730	735	707.04
	FLR6A-ZF 15-TFM	ZF15KQE-TFD-551	145	1095	475	820	1130	630
	FLR6A-ZF 18-TFM	ZF18KQE-TFD-551	147	1095	475	820	1130	630
	FLR7A-ZF 18-TFM	ZF18KQE-TFD-551	147	1095	475	820	1130	630
	FLR7A-ZF 25-TFM	ZF25KQE-TFD-551	147	1095	475	820	1130	630
	FLS9A-ZF 25-TFM	ZF25KQE-TFD-551	159	1095	475	820	1130	706
	FLV9A-ZF 34-TFM	ZF34KQE-TFD-564	230	1294	475	820	1329	832
	FLV6A-ZF 34-TFM	ZF34KQE-TFD-564	247	1294	475	820	1329	832
	FLV6A-ZF 41-TFM	ZF41KQE-TFD-564	251	1294	475	820	1329	832

*Mechanical data - 60Hz*

Medium temperature	Description	Compressor model	Gross weight (kg)	b	t	D	W	H
	FMH8A-ZB 15-TF7	ZB15KQE-TF7-559	79	700	370	679.5	735	531
	FMM8A-ZB 19-TF7	ZB19KQE-TF7-559	91	700	390	730	735	707.04
	FMM8A-ZB 21-TF7	ZB21KQE-TF7-559	91	700	390	730	735	707.04
	FMR6A-ZB 26-TF7	ZB26KQE-TF7-559	135	1095	475	820	1130	630
	FMR7A-ZB 29-TF7	ZB29KQE-TF7-559	139	1095	475	820	1130	630
	FMS9A-ZB 38-TF7	ZB38KQE-TF7-559	155	1095	475	820	1130	706
	FMV6A-ZB 58-TF7	ZB58KQE-TF7-551	244	1294	475	820	1329	832
	FMV6A-ZB 66-TF7	ZB66KQE-TF7-551	246	1294	475	820	1329	832
	FMV9A-ZB 45-TF7	ZB45KQE-TF7-559	208	1294	475	820	1329	832
	FMV9A-ZB 48-TF7	ZB48KQE-TF7-559	209	1294	475	820	1329	832

Low temperature	Description	Compressor model	Gross weight (kg)	b	t	D	W	H
	FLH7A-ZF 06-CFV	ZF06K4E-PFV-551	82	700	370	679.5	735	531
	FLH8A-ZF 09-CFV	ZF09K4E-PFV-551	83	700	370	679.5	735	531
	FLM8A-ZF 11-CFV	ZF11K4E-PFV-551	93	700	390	730	735	707.04
	FLM8A-ZF 13-TF7	ZF13KQE-TF7-551	104	700	390	730	735	707.04
	FLR6A-ZF 13-TF7	ZF13KQE-TF7-551	146	1095	475	820	1130	630
	FLR7A-ZF 15-TF7	ZF15KQE-TF7-551	146	1095	475	820	1130	630
	FLS9A-ZF18-TF7	ZF18KQE-TF7-551	158	1095	475	820	1130	706

## ***Installation, system processing and commissioning***

Utmost care must be taken while handling the scroll condensing unit.

Please go through the contents below to ensure proper handling:

### ***Leak test, evacuation and charging***

The following assumes the condensing unit to be leak-free on arrival. That is an important step before proceeding with the following.

Leak test is particularly important for field-connected systems. Typically, field systems lose as much as 20%-30% of their refrigeration charge annually. This is not only an unnecessary expense but also damages the environment. Compressor oil can be lost at the same time as refrigerant and eventually lead to compressor failure. (Time spent on leak test will eventually reduce the time spent on the evacuation process).

Ensure that all service valves are open during the leak test process. It is important to recheck all joints within the unit as well as the external joints.

### ***Initial pressure test (by vacuum and nitrogen)***

#### **Step-by-step**

1. Use a 4-port gauge manifold with 3/8" hose and connections to the vacuum pump. The vacuum gauge does not have to be connected for this part of the process.
2. Connect the gauges to service ports provided on receiver valve and suction tube.

In order to remove any non-condensable that may have entered the system during installation, follow these steps:

- \* Start the vacuum pump. The evaporator fan should be running and the compressor crankcase heater is energized at this point. This will involve powering up the unit, so it is important to disconnect the live feed wire to the compressor contactor (so the compressor cannot run and the crankcase heater can be energized).
3. Open both valves on the manifold and then open the main vacuum valve on the pump. Run the system until the vacuum level of -0.85 bar (as read on manifold gauge) is achieved.
  4. Shut off the main vacuum pump valve. Check for vacuum rise using the manifold compound gauge. A rise would indicate a large leak.
  5. If vacuum holds for 10 minutes, break vacuum with nitrogen and pressurize to 20 bar. Check for leaks and repair leakage.

### Leak test (by nitrogen pressure)

Release nitrogen from system. Start vacuum pump and open main pump valve.

### Evacuation

Note that the following procedure is based upon achieving an actual system vacuum standard and it is NOT TIME-DEPENDENT!

#### Step-by-step:

1. Check suction capability of the vacuum pump with a gauge before commencing evacuation process. The vacuum pump must be rated to achieve a vacuum level of at least 100 µmHg (microns) or 13 Pa.
2. Connect the vacuum gauge to the system.
3. It is recommended to carry out the evacuation process three times as detailed below: Start the vacuum pump and then open the main valve. It is assumed that the crank case heater is still energized and the compressor cannot start.



**Caution** Ensure that the vacuum pump cannot be switched off during evacuation. Otherwise, the pump may lose its lubrication oil to the system and contaminate it. Therefore, the pump must have a vacuum breaker fitted to it.

4. Step 1 Evacuation: Evacuate to 1500 µmHg (microns) or 200 Pa and break vacuum to 0.1 bar with Nitrogen
5. Step 2 Evacuation: Same as in step 1
6. Step 3 Evacuation: Leave the pump running while checking the vacuum regularly. The target system vacuum is 500 µmHg (microns) or 67 Pa.

Once the target vacuum level is reached, the quality of the vacuum within the system must be tested. This is achieved by shutting off the main pump valve, allowing the internal system pressure to rise, and recording the time taken for the vacuum to rise by no more than 300 µmHg (microns) or 40 Pa within 30 minutes. (i.e. to 100 µmHg (microns) or 13.3 Pa). Evacuation is only complete once the vacuum quality is achieved. Close the manifold valves tightly. Close the pump main valve, switch off, and remove the vacuum pump.

### Charging and commissioning

#### Step-by-step:

1. Ensure that there is no power supply to the unit. Hence, it is acceptable to leave the crankcase heater off.
2. Connect the refrigerant cylinder to main service hose and purge line at the manifold end.
3. Invert the refrigerant cylinder if necessary to ensure only liquid refrigerant can be charged into the system. This will be charged through the high pressure side of the manifold and liquid service valve.
4. The refrigerant cylinder should be weighed at this point to be able to record the final refrigerant charge. Refer to the table below for the approximate holding capacity of receiver is at 32°C when it is 80% full. Now, open the liquid service valve (off the back seat). In warm ambients, with a good vacuum in the system and the refrigerant cylinder inverted, it may not be necessary to run the compressor.

5. In cooler ambients, it may be necessary to run the compressor in order to complete charging.

**IMPORTANT! TO BE CLEARLY UNDERSTOOD PRIOR TO RUNNING ANY SCROLL COMPRESSOR**

Scroll compressor systems should be charged as quickly as possible by bleeding liquid refrigerant into the suction line with the compressor running.

**DO NOT VAPOR CHARGE SCROLL CONDENSING UNIT SYSTEM!**

6. The system needs to be operated down to its set point before you can be sure that the charge is correct. It is at this point that the normal refrigeration operational checks can be carried out—such as checking the liquid line sight glass for bubbles and the operating pressures.
7. If the system is still short of the refrigerant, bleed liquid refrigerant into the suction side with the compressor running.
8. Check the oil level and add oil if necessary.

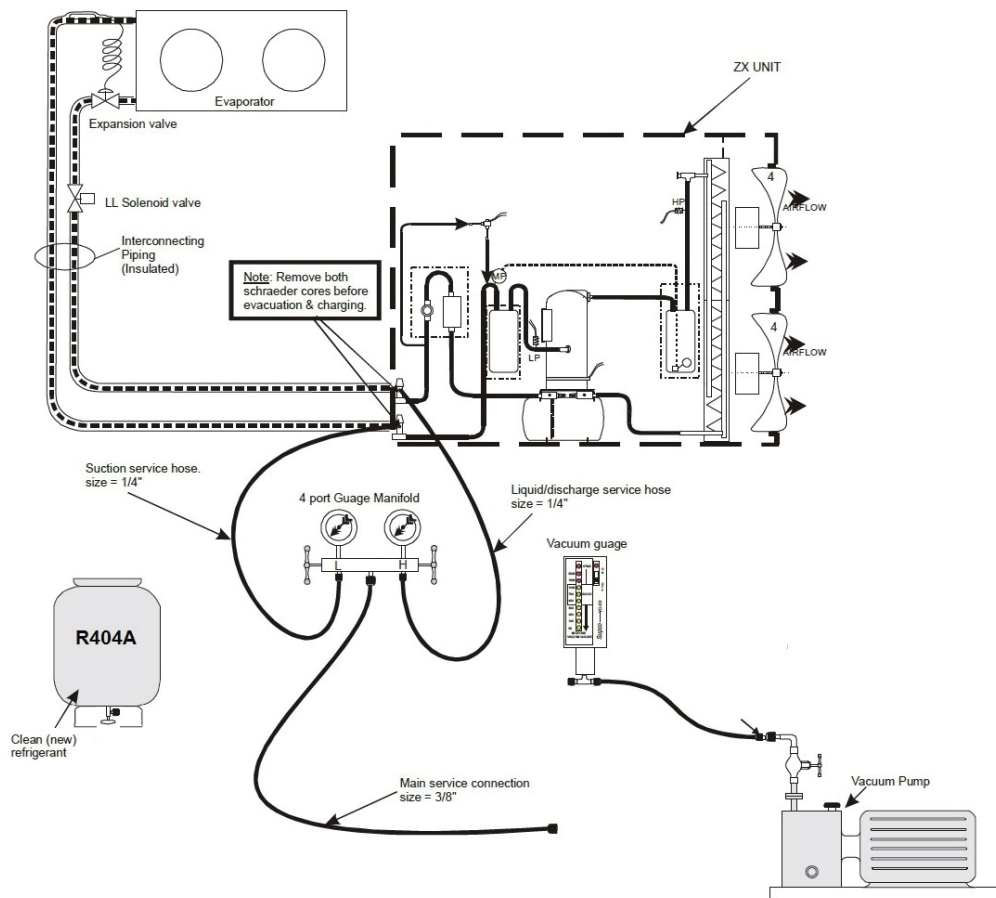



## Unit operation

Before starting the unit, ensure the following:

- All the electrical connections are correct and as per the recommended wiring diagrams
- All low side tubings are properly insulated
- Leak check is done and unit is pre-charged with refrigerant through high side
- Check for superheat setting on the expansion valve (TXV) appropriate or not

Adding refrigerant on a cold weather results to an overcharged unit, which may then trip out on high pressure limit during warm weather.

Suction Superheat should be 10–15 K for reliable operation.



Remember that the refrigerant is under pressure. Always wear protective equipment, i.e. safety glasses or goggles and gloves when working with refrigerant, and guard against refrigerant spraying into the face or skin. Line pressures on an operating conditioning unit will vary with outdoor temperatures. As outdoor temperatures rise, pressures will also rise.

### Caution



**DO NOT, UNDER ANY CIRCUMSTANCES, HEAT THE REFRIGERANT CYLINDER WITH A TORCH OR BY ANY OTHER MEANS OTHER THAN WARM WATER. EXCESSIVE PRESSURES GENERATED IN THIS MANNER MAY WEAKEN THE REFRIGERANT CONTAINER AND RESULT TO A CYLINDER EXPLOSION!**

## Application tips for scroll compressors

- Do not use compressor to pull vacuum
- Never use the compressor to suck oil into the system
- Do not test compressor by closing suction valve
- Do not set low pressure switch below 0 bar
- Do not bypass LP controls
- Do not pump down below 0 bar
- Reverse Rotation
  - Incorrect rotation can be identified by:  
Low current, noise, balanced suction, and discharge pressure;
  - Correct by interchanging any two phases
  - Short-term reverse rotation will not damage the compressor



***Approved compressor oil***

POE-32: Polyolester oil (Copeland Ultra 32-3MAF, Lubrizol Emkarate RL32-3MAF, Everest

32-3MAF, National NL PE32-3MAF, Parker EMKARATE RL32-3MAF/ (Virginia) LE323MAF, Nu Calgon 4314-66/EMKARATE RL32-3MAF, Everest 22 CC, Copeland Ultra 22 CC, Mobil Arctic 22 CC). Last three are approved for 'top off' only, 32-3MAF preferred.

***High and low pressure control settings***

<b>Model</b>	<b>Control type</b>	<b>R-404A/507</b>	<b>R-134A</b>	<b>R-22 / R-407A / R-407C / R407F / R-448A / R-449A</b>
ZF* K5E	Low	0 psig min.	---	2 in. Hg min.
	High	400 psig min.		335 psig max.
ZB*K5E	Low	17 psig min.	4 psig min.	37 psig min.
	High	450 psig max	263 psig max	381 psig max

### ***Condenser fins***

Condenser fins become dirty over time as ambient air is induced to the condenser. Dirty coil surfaces result in high condensing temperatures and poor unit performance. Regular cleaning is recommended with frequency depending on the installation and the surrounding environment. As a general guide, it is advisable to do this at least once every two months.

Fins should be cleaned with liquid detergent diluted with clean water. Before washing, a light brush downward (in the direction of the fins) should be done to remove heavy deposits. Electrical Connections Check tightness of electrical connections occasionally.

### ***Routine leak test***

All joints should be checked for leaks during site visits. All joints should be leak tested once a year. Condenser Fan(s) and Motor(s) An annual inspection of these items is recommended. Fastenings may loosen, bearings may wear, and fans may require cleaning of solid deposits which can cause imbalance.



**TURN OFF OR DISCONNECT THE ELECTRICAL POWER SOURCE BEFORE CLEANING THE CONDENSER COIL OR DOING MAINTENANCE.**

F Series Condensing Unit	TFM	TF7	052-2988-01
Compressor	CR-TFM/D//KCM-E//ZB,ZS,ZF-TFD	ZB,ZS,ZF-TF7	
X1 (L-N)	230 ± 10% V/1/50Hz	230 ± 10% V/1/60Hz	
X2 (L1-L2-L3)	400 ± 10% V/3/50Hz	380 ± 10% V/3/60Hz	Rev 00

Remarks:

- A5 = Terminal Box Condensing Unit
- A7 = Terminal Box Condensing Unit
- B1 = Room Thermostat
- C1 = Run Capacitor M21/M22
- F3 = Pressure Control Switch
- F11 = Internal Over-Current Thermal Protector
- F13 = Discharge Gas Thermostat (If Fitted)
- H4 = Signal Lamp F3 High Discharge Pressure (If Fitted)
- K1 = Contactor M1
- K51 = Contactor M21
- K52 = Contactor M22
- K6 = Relay Unit Alarm (If Fitted)
- M1 = Compressor Motor
- M21 = Fan Motor / Condenser
- M22 = Fan Motor / Condenser
- N1 = Speed Control Fan (If Fitted)
- R2 = Crankcase Heater
- X1 = Terminal Block
- X2 = Terminal Block

Condenser: B8

Fan: 71

Condenser: C8,D8,H7,R6

Fan: 121

Cable Colours:

WH = White	BU = Blue	LGY = Light Grey
GY = Grey	RD = Red	CGY = Charcoal Grey
BK = Black	YE = Yellow	
BN = Brown	G/Y = Green/Yellow	

F Series Condensing Unit	TFM	TF7	052-2988-02
Compressor	CR-TFM/D//KCM-E//ZB,ZS,ZF-TFD	ZB,ZS,ZF-TF7	
X1 (L-N)	230 ± 10% V/1/50Hz	230 ± 10% V/1/60Hz	
X2 (L1-L2-L3)	400 ± 10% V/3/50Hz	380 ± 10% V/3/60Hz	Rev 00

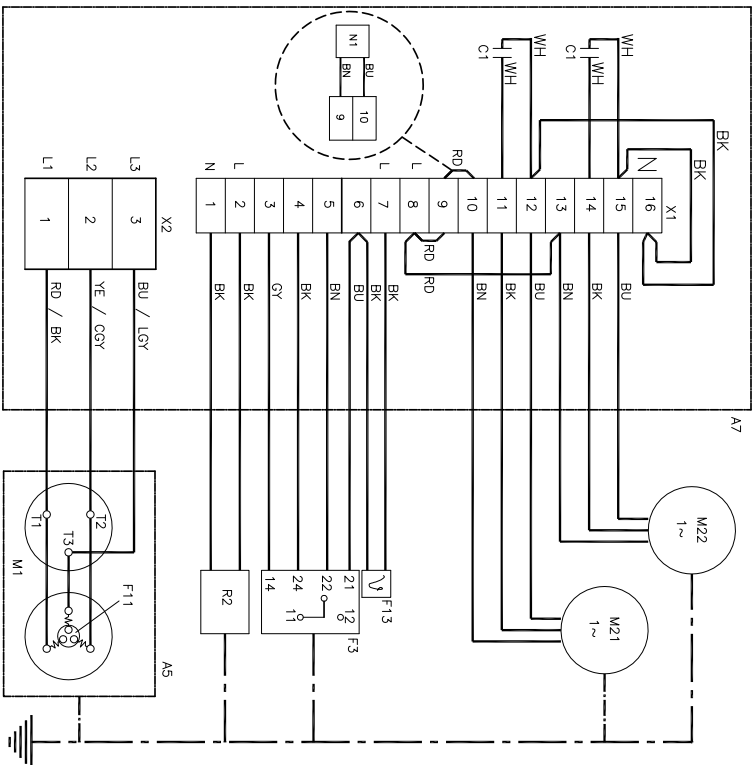

Remarks:

- A5 = Terminal Box Compressor
- A7 = Terminal Box Condensing Unit
- B1 = Room Thermostat
- C1 = Run Capacitor M21/M22
- F3 = Pressure Control Switch
- F11 = Internal Over-Current Thermal Protector
- F13 = Discharge Gas Thermostat (If Fitted)
- H4 = Signal Lamp F3 High Discharge Pressure (If Fitted)
- K1 = Contactor M1
- K51 = Contactor M21
- K52 = Contactor M22
- K6 = Relay Unit Alarm (If Fitted)
- M1 = Compressor Motor
- M21 = Fan Motor / Condenser
- M22 = Fan Motor / Condenser
- N1 = Speed Control Fan (If Fitted)
- R2 = Crankcase Heater
- X1 = Terminal Block
- X2 = Terminal Block

Typical Control Circuit

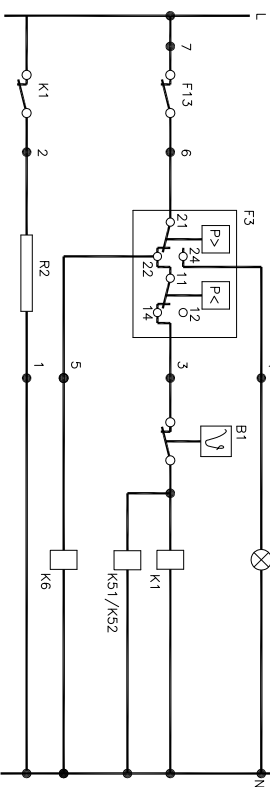

Condenser: H8,M8,R7,S9,V9	271 Fan
Condenser: V6,W9	611 Fan
Cable Colours:	
WH = White	BU = Blue
GY = Grey	RD = Red
BK = Black	YE = Yellow
BN = Brown	G/Y = Green/Yellow



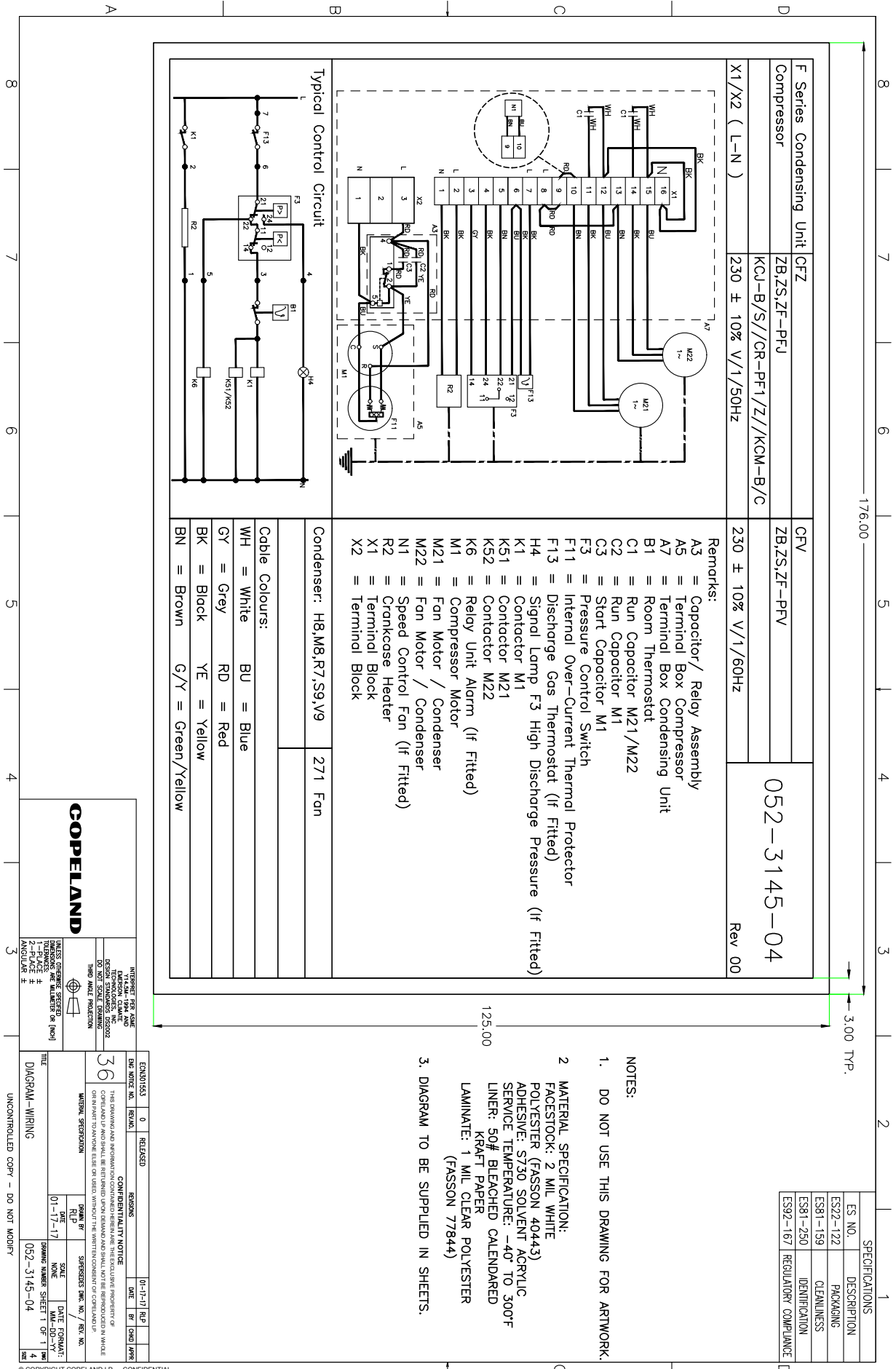

**36**

THIS DRAWING AND INFORMATION CONTAINED HEREIN IS THE PROPERTY OF COPPELAND LP AND SHALL BE RETURNED UPON DEMAND AND SHALL NOT BE REPRODUCED OR IN ANY MANNER TO ANYONE ELSE OR USED WITHOUT THE WRITTEN CONSENT OF COPPELAND LP.

**COPPELAND**

UNLESS OTHERWISE SPECIFIED OR INDICATED BY DIMENSIONS OR TOLERANCES, ALL DIMENSIONS ARE IN INCHES UNLESS INDICATED OTHERWISE.

1 - 1/4" DIA. - 1/8" DIA. AND SMALLER - 0.0005" TOLERANCE  
1/4" - 1/2" DIA. - 0.0015" TOLERANCE  
3/4" - 1" DIA. - 0.0025" TOLERANCE  
1" - 2" DIA. - 0.0035" TOLERANCE  
2" - 4" DIA. - 0.0045" TOLERANCE  
4" - 6" DIA. - 0.0055" TOLERANCE  
6" - 12" DIA. - 0.0065" TOLERANCE  
12" - 24" DIA. - 0.0075" TOLERANCE  
24" - 48" DIA. - 0.0085" TOLERANCE  
48" - 96" DIA. - 0.0095" TOLERANCE  
96" - 192" DIA. - 0.0105" TOLERANCE  
192" - 384" DIA. - 0.0115" TOLERANCE  
384" - 768" DIA. - 0.0125" TOLERANCE  
768" - 1536" DIA. - 0.0135" TOLERANCE  
1536" - 3072" DIA. - 0.0145" TOLERANCE  
3072" - 6144" DIA. - 0.0155" TOLERANCE  
6144" - 12288" DIA. - 0.0165" TOLERANCE  
12288" - 24576" DIA. - 0.0175" TOLERANCE  
24576" - 49152" DIA. - 0.0185" TOLERANCE  
49152" - 98304" DIA. - 0.0195" TOLERANCE  
98304" - 196608" DIA. - 0.0205" TOLERANCE  
196608" - 393216" DIA. - 0.0215" TOLERANCE  
393216" - 786432" DIA. - 0.0225" TOLERANCE  
786432" - 1572864" DIA. - 0.0235" TOLERANCE  
1572864" - 3145728" DIA. - 0.0245" TOLERANCE  
3145728" - 6291456" DIA. - 0.0255" TOLERANCE  
6291456" - 12582912" DIA. - 0.0265" TOLERANCE  
12582912" - 25165824" DIA. - 0.0275" TOLERANCE  
25165824" - 50331648" DIA. - 0.0285" TOLERANCE  
50331648" - 100663296" DIA. - 0.0295" TOLERANCE  
100663296" - 201326592" DIA. - 0.0305" TOLERANCE  
201326592" - 402653184" DIA. - 0.0315" TOLERANCE  
402653184" - 805306368" DIA. - 0.0325" TOLERANCE  
805306368" - 1610612736" DIA. - 0.0335" TOLERANCE  
1610612736" - 3221225472" DIA. - 0.0345" TOLERANCE  
3221225472" - 6442450944" DIA. - 0.0355" TOLERANCE  
6442450944" - 12884901888" DIA. - 0.0365" TOLERANCE  
12884901888" - 25769803776" DIA. - 0.0375" TOLERANCE  
25769803776" - 51539607552" DIA. - 0.0385" TOLERANCE  
51539607552" - 103079215104" DIA. - 0.0395" TOLERANCE  
103079215104" - 206158430208" DIA. - 0.0405" TOLERANCE  
206158430208" - 412316860416" DIA. - 0.0415" TOLERANCE  
412316860416" - 824633720832" DIA. - 0.0425" TOLERANCE  
824633720832" - 1649267441664" DIA. - 0.0435" TOLERANCE  
1649267441664" - 3298534883328" DIA. - 0.0445" TOLERANCE  
3298534883328" - 6597069766656" DIA. - 0.0455" TOLERANCE  
6597069766656" - 13194139533312" DIA. - 0.0465" TOLERANCE  
13194139533312" - 26388279066624" DIA. - 0.0475" TOLERANCE  
26388279066624" - 52776558133248" DIA. - 0.0485" TOLERANCE  
52776558133248" - 105553116266496" DIA. - 0.0495" TOLERANCE  
105553116266496" - 211106232532992" DIA. - 0.0505" TOLERANCE  
211106232532992" - 422212465065984" DIA. - 0.0515" TOLERANCE  
422212465065984" - 844424930131968" DIA. - 0.0525" TOLERANCE  
844424930131968" - 1688849860263936" DIA. - 0.0535" TOLERANCE  
1688849860263936" - 3377699720527872" DIA. - 0.0545" TOLERANCE  
3377699720527872" - 6755399441055744" DIA. - 0.0555" TOLERANCE  
6755399441055744" - 13510798882111488" DIA. - 0.0565" TOLERANCE  
13510798882111488" - 27021597764222976" DIA. - 0.0575" TOLERANCE  
27021597764222976" - 54043195528445952" DIA. - 0.0585" TOLERANCE  
54043195528445952" - 108086391056891904" DIA. - 0.0595" TOLERANCE  
108086391056891904" - 216172782113783808" DIA. - 0.0605" TOLERANCE  
216172782113783808" - 432345564227567616" DIA. - 0.0615" TOLERANCE  
432345564227567616" - 864691128455135232" DIA. - 0.0625" TOLERANCE  
864691128455135232" - 1729382256910270464" DIA. - 0.0635" TOLERANCE  
1729382256910270464" - 3458764513820540928" DIA. - 0.0645" TOLERANCE  
3458764513820540928" - 6917529027641081856" DIA. - 0.0655" TOLERANCE  
6917529027641081856" - 13835058055282163712" DIA. - 0.0665" TOLERANCE  
13835058055282163712" - 27670116110564327424" DIA. - 0.0675" TOLERANCE  
27670116110564327424" - 55340232221128654848" DIA. - 0.0685" TOLERANCE  
55340232221128654848" - 110680464442257309696" DIA. - 0.0695" TOLERANCE  
110680464442257309696" - 221360928884514619392" DIA. - 0.0705" TOLERANCE  
221360928884514619392" - 442721857769029238784" DIA. - 0.0715" TOLERANCE  
442721857769029238784" - 885443715538058477568" DIA. - 0.0725" TOLERANCE  
885443715538058477568" - 1770887431076116955136" DIA. - 0.0735" TOLERANCE  
1770887431076116955136" - 3541774862152233910272" DIA. - 0.0745" TOLERANCE  
3541774862152233910272" - 7083549724304467820544" DIA. - 0.0755" TOLERANCE  
7083549724304467820544" - 14167099448608935641088" DIA. - 0.0765" TOLERANCE  
14167099448608935641088" - 28334198897217871282176" DIA. - 0.0775" TOLERANCE  
28334198897217871282176" - 56668397794435742564352" DIA. - 0.0785" TOLERANCE  
56668397794435742564352" - 113336795588871485128704" DIA. - 0.0795" TOLERANCE  
113336795588871485128704" - 226673591177742970257408" DIA. - 0.0805" TOLERANCE  
226673591177742970257408" - 453347182355485940514816" DIA. - 0.0815" TOLERANCE  
453347182355485940514816" - 906694364710971881029632" DIA. - 0.0825" TOLERANCE  
906694364710971881029632" - 1813388729421943762059264" DIA. - 0.0835" TOLERANCE  
1813388729421943762059264" - 3626777458843887524118528" DIA. - 0.0845" TOLERANCE  
3626777458843887524118528" - 7253554917687775048237056" DIA. - 0.0855" TOLERANCE  
7253554917687775048237056" - 14507109835375550096474112" DIA. - 0.0865" TOLERANCE  
14507109835375550096474112" - 29014219670751100192948224" DIA. - 0.0875" TOLERANCE  
29014219670751100192948224" - 58028439341502200385896448" DIA. - 0.0885" TOLERANCE  
58028439341502200385896448" - 116056878683004400771792896" DIA. - 0.0895" TOLERANCE  
116056878683004400771792896" - 232113757366008801543585792" DIA. - 0.0905" TOLERANCE  
232113757366008801543585792" - 464227514732017603087171584" DIA. - 0.0915" TOLERANCE  
464227514732017603087171584" - 928455029464035206174343168" DIA. - 0.0925" TOLERANCE  
928455029464035206174343168" - 1856910058928070412388686336" DIA. - 0.0935" TOLERANCE  
1856910058928070412388686336" - 3713820117856140824777372672" DIA. - 0.0945" TOLERANCE  
3713820117856140824777372672" - 7427640235712281649554745344" DIA. - 0.0955" TOLERANCE  
7427640235712281649554745344" - 14855280471425763299094910688" DIA. - 0.0965" TOLERANCE  
14855280471425763299094910688" - 29710560942851526598189821376" DIA. - 0.0975" TOLERANCE  
29710560942851526598189821376" - 59421121885703053196379642752" DIA. - 0.0985" TOLERANCE  
59421121885703053196379642752" - 118842243771406106392753255504" DIA. - 0.0995" TOLERANCE  
118842243771406106392753255504" - 237684487542812212785506511008" DIA. - 0.1005" TOLERANCE  
237684487542812212785506511008" - 475368975085624425571013022016" DIA. - 0.1015" TOLERANCE  
475368975085624425571013022016" - 950737950171248851142026044032" DIA. - 0.1025" TOLERANCE  
950737950171248851142026044032" - 1901475900342497702284052088064" DIA. - 0.1035" TOLERANCE  
1901475900342497702284052088064" - 3802951800684995404568104176128" DIA. - 0.1045" TOLERANCE  
3802951800684995404568104176128" - 7605903601369990809136208352256" DIA. - 0.1055" TOLERANCE  
7605903601369990809136208352256" - 15211807202739981618272416704512" DIA. - 0.1065" TOLERANCE  
15211807202739981618272416704512" - 30423614405479963236544833409024" DIA. - 0.1075" TOLERANCE  
30423614405479963236544833409024" - 60847228810959926473089666818048" DIA. - 0.1085" TOLERANCE  
60847228810959926473089666818048" - 121694457621919852946179333636096" DIA. - 0.1095" TOLERANCE  
121694457621919852946179333636096" - 243388915243839705892358667272192" DIA. - 0.1105" TOLERANCE  
243388915243839705892358667272192" - 486777830487679411784717334544384" DIA. - 0.1115" TOLERANCE  
486777830487679411784717334544384" - 973555660975358823569434669088768" DIA. - 0.1125" TOLERANCE  
973555660975358823569434669088768" - 1947111321950717647138869338177536" DIA. - 0.1135" TOLERANCE  
1947111321950717647138869338177536" - 389422264390143529427773867635472" DIA. - 0.1145" TOLERANCE  
389422264390143529427773867635472" - 778844528780287058855547735270944" DIA. - 0.1155" TOLERANCE  
778844528780287058855547735270944" - 1557689057560574117711095470541888" DIA. - 0.1165" TOLERANCE  
1557689057560574117711095470541888" - 311537811512114823542219094107376" DIA. - 0.1175" TOLERANCE  
311537811512114823542219094107376" - 623075623024229647084438188214752" DIA. - 0.1185" TOLERANCE  
623075623024229647084438188214752" - 124615124604845929416887637642944" DIA. - 0.1195" TOLERANCE  
124615124604845929416887637642944" - 249230249209691858833775275285888" DIA. - 0.1205" TOLERANCE  
249230249209691858833775275285888" - 498460498419383717667550550571776" DIA. - 0.1215" TOLERANCE  
498460498419383717667550550571776" - 99692099683876743533510110114352" DIA. - 0.1225" TOLERANCE  
99692099683876743533510110114352" - 199384199367753487067020220228704" DIA. - 0.1235" TOLERANCE  
199384199367753487067020220228704" - 398768398735506974134040440457408" DIA. - 0.1245" TOLERANCE  
398768398735506974134040440457408" - 797536797471013948268080880914816" DIA. - 0.1255" TOLERANCE  
797536797471013948268080880914816" - 1595073594942027896536161761829632" DIA. - 0.1265" TOLERANCE  
1595073594942027896536161761829632" - 3190147189884055793072323523659264" DIA. - 0.1275" TOLERANCE  
3190147189884055793072323523659264" - 6380294379768111586144646447318528" DIA. - 0.1285" TOLERANCE  
6380294379768111586144646447318528" - 12760588759536223172288922894637056" DIA. - 0.1295" TOLERANCE  
12760588759536223172288922894637056" - 25521177519072446344577845789274112" DIA. - 0.1305" TOLERANCE  
25521177519072446344577845789274112" - 51042355038144892689155691578548224" DIA. - 0.1315" TOLERANCE  
51042355038144892689155691578548224" - 102084710076289785378311383157096448" DIA. - 0.1325" TOLERANCE  
102084710076289785378311383157096448" - 204169420152579570756622766314192896" DIA. - 0.1335" TOLERANCE  
204169420152579570756622766314192896" - 408338840305159141513245532628385792" DIA. - 0.1345" TOLERANCE  
408338840305159141513245532628385792" - 816677680610318283026491065256771536" DIA. - 0.1355" TOLERANCE  
816677680610318283026491065256771536" - 163335536122063656605298213051344576" DIA. - 0.1365" TOLERANCE  
163335536122063656605298213051344576" - 32667107224412731321057642610269152" DIA. - 0.1375" TOLERANCE  
32667107224412731321057642610269152" - 65334214448825462642111485220538304" DIA. - 0.1385" TOLERANCE  
65334214448825462642111485220538304" - 13066842889765092528422296440106608" DIA. - 0.1395" TOLERANCE  
13066842889765092528422296440106608" - 261336857795301850568445928802133216" DIA. - 0.1405" TOLERANCE  
261336857795301850568445928802133216" - 522673715590603701137691857604264384" DIA. - 0.1415" TOLERANCE  
522673715590603701137691857604264384" - 1045347431181207402275383715208496768" DIA. - 0.1425" TOLERANCE  
1045347431181207402275383715208496768" - 209069486236241480455076743041793536" DIA. - 0.1435" TOLERANCE  
209069486236241480455076743041793536" - 418138972472482960910153486083587072" DIA. - 0.1445" TOLERANCE  
418138972472482960910153486083587072" - 836277944944965921820306972167174144" DIA. - 0.1455" TOLERANCE  
836277944944965921820306972167174144" - 1672555889889931843640613944334348288" DIA. - 0.1465" TOLERANCE  
1672555889889931843640613944334348288" - 334511177977986368728122688866868656" DIA. - 0.1475" TOLERANCE  
334511177977986368728122688866868656" - 669022355955972737456253377733737312" DIA. - 0.1485" TOLERANCE  
669022355955972737456253377733737312" - 133804471191194547491250675546746464" DIA. - 0.1495" TOLERANCE  
133804471191194547491250675546746464" - 267608942382389094982501351093492928" DIA. - 0.1505" TOLERANCE  
267608942382389094982501351093492928" - 535217884764778189965002702186985856" DIA. - 0.1515" TOLERANCE  
535217884764778189965002702186985856" - 1070435769529556379930005444373971712" DIA. - 0.1525" TOLERANCE  
1070435769529556379930005444373971712" - 2140871539059112759860010888747943424" DIA. - 0.1535" TOLERANCE  
2140871539059112759860010888747943424" - 428174307811822551972002177749586848" DIA. - 0.1545" TOLERANCE  
428174307811822551972002177749586848" - 85634861562364510394400435549973696" DIA. - 0.1555" TOLERANCE  
85634861562364510394400435549973696" - 171269723124729020788800871099473984" DIA. - 0.1565" TOLERANCE  
171269723124729020788800871099473984" - 342539446249458041577601742198947968" DIA. - 0.1575" TOLERANCE  
342539446249458041577601742198947968" - 68507889249891608315520348439789536" DIA. - 0.1585" TOLERANCE  
68507889249891608315520348439789536" - 137015778499783216631040688879579072" DIA. - 0.1595" TOLERANCE  
137015778499783216631040688879579072" - 274031556999566432622081377759158144" DIA. - 0.1605" TOLERANCE  
274031556999566432622081377759158144" - 5480631139991328652441627555183168" DIA. - 0.1615" TOLERANCE  
5480631139991328652441627555183168" - 1096126227998265730488325511066336" DIA. - 0.1625" TOLERANCE  
1096126227998265730488325511066336" - 2192252455996531460976651022132672" DIA. - 0.1635" TOLERANCE  
2192252455996531460976651022132672" - 438450491199306292195330204426544" DIA. - 0.1645" TOLERANCE  
438450491199306292195330204426544" - 876900982398612584390660408853088" DIA. - 0.1655" TOLERANCE  
876900982398612584390660408853088" - 1753801964797225168781320817706176" DIA. - 0.1665" TOLERANCE  
1753801964797225168781320817706176" - 3507603929594450337562641635412352" DIA. - 0.1675" TOLERANCE  
3507







## About Copeland

Copeland is a global leader in sustainable heating, cooling, refrigeration and industrial solutions. We help commercial, industrial, refrigeration and residential customers reduce their carbon emissions and improve energy efficiency. We address issues like climate change, growing populations, electricity demands and complex global supply chains with innovations that advance the energy transition, accelerate the adoption of climate friendly low GWP (Global Warming Potential) and natural refrigerants, and safeguard the world's most critical goods through an efficient and sustainable cold chain. We have over 18,000 employees, with feet on the ground in 50 countries - a global presence that makes it possible to serve customers wherever they are in the world and meet challenges with scale and speed. Our industry-leading brands and diversified portfolio deliver innovation and technology proven in over 200 million installations worldwide. Together, we create sustainable solutions that improve lives and protect the planet today and for future generations. For more information, visit [copeland.com](https://www.copeland.com).

Follow us:



**To learn more, visit [copeland.com](https://www.copeland.com)**

8530158 (2020/MEA/66) F-series scroll condensing units  
©2024 Copeland LP.

**COPELAND**